



**Rotary Geared
Flow Divider/Combiners**
Introduction



Accurate.
Efficient.
Easy Installation.



Rotary Geared Flow Divider/Combiners

Related Fluid Power rotary geared flow dividers have been designed to accurately divide flow from a single hydraulic source into two or more separate output flows. Compared to spool type flow dividers, which rely on high pressure drop to achieve their function, rotary geared flow dividers are a highly efficient solution (up to 98% efficiency is not uncommon) for dividing flows with minimal energy loss and heat generation.

Flow Divider and Combiner

Unlike most spool type flow dividers, rotary geared flow dividers will also combine return flows to allow the synchronising of actuators in both directions of movement.

Equal, Mixed and Multi-Section

Dependant on the type of unit flows from 2 to 600 litres can be divided exactly in two or up to a maximum of eight equal or proportionately mixed flows.

A Flow Divider as an Intensifier

By off-loading one output from a 2-section flow divider to tank enables service output pressure to be intensified. The ratio of the displacements of the flow divider sections is a measure of the amount of intensification obtained.

Flow Dividers with Integral Reliefs

To allow a "lagging" cylinder to catch up quickly at end of stroke Related Fluid Power flow dividers can be supplied with integral differential reliefs which relieve back into the inlet gallery of the unit.

Features

- Proven design, stable material selection and precise machining are the keys to quiet, reliable performance in a variety of applications.
- Precision machined gears and gear sections.
- High strength permanent mould cast iron housing.
- Precision needle bearings.
- Hardened shafts joined by internally hardened round keys and keyways to eliminate stress concentrations and wear.
- Precise machined trapping relief grooves provide constant filling and discharging to assure quiet operation and maximum bearing life.
- O-ring seals between sections.
- Precision dowel pin alignment between sections.

Our Markets

- Material Handling
- Access Platforms
- Lifts
- On & Off Highway Vehicles
- Mining & Construction
- Waste Management
- Aircraft Ground Support
- Light Industrial
- Presses
- Agriculture



Specifications

- Sections per unit: 2 to 8 sections.
- Displacements: 1.1 to 64 cm³ /rev per section.
- Pressures: up to 240 bar (420 bar intermittent).

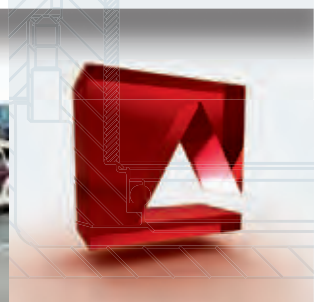
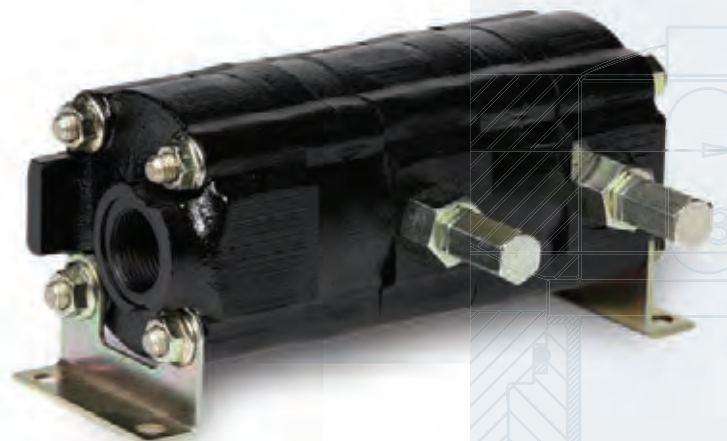

Typical Schematics

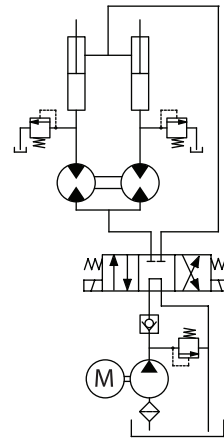
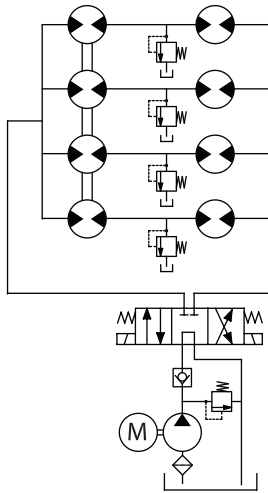

Multiple Motor Control

Where one pump operates a number of hydraulic motors: car wash systems, lubrication systems (multiple point), hydraulic driven machines – harvesting machines, earth moving machines, etc.

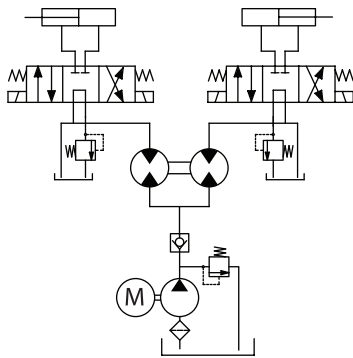

Synchronising Cylinders

Where two or more cylinders must be synchronised: lift platforms, scaffolds, presses, etc.

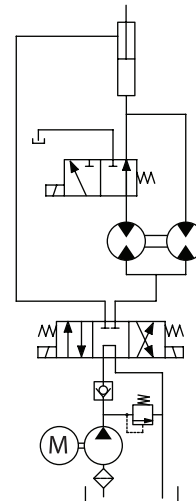

Independent Circuit Control

Where two or more circuits must be controlled independently at different pressures/flows: presses, machine tools, etc.

Pressure Intensification

Where main pump pressure must be intensified in one circuit of multiple circuit machinery, such as waste compactors and other hi-lo applications.

Synchronising Cylinders Using Integral Reliefs

Where it is important for “lagging” cylinders to “catch up” at end of stroke P Series flow dividers with integral differential reliefs can be used: demount and stabiliser control circuits, lift platforms, presses, etc.

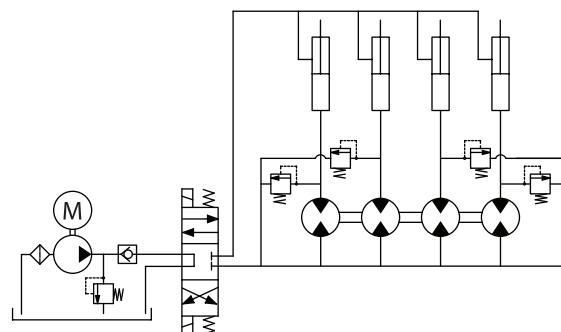



Related Fluid Power Ltd

Cuparmuir
Cupar
Fife
UK
KY15 5SL

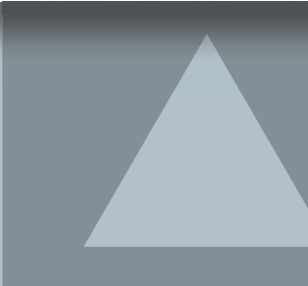

Tel: +44 (0)1334 655 600
Fax: +44 (0)1334 650 006
Email: sales@relatedfluidpower.com
Web: www.relatedfluidpower.com

